

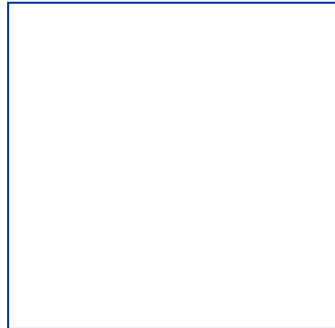

DORIN®

i n n o v a t i o n

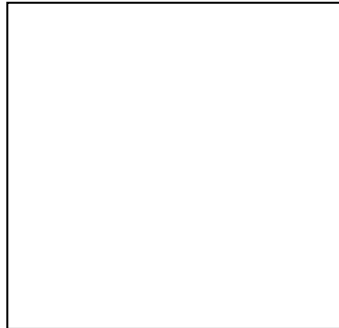
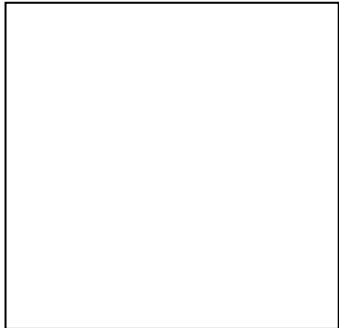
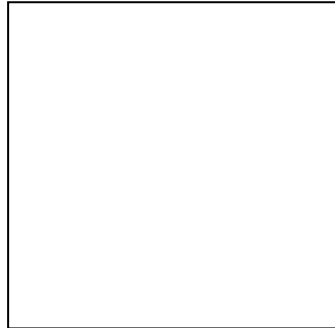
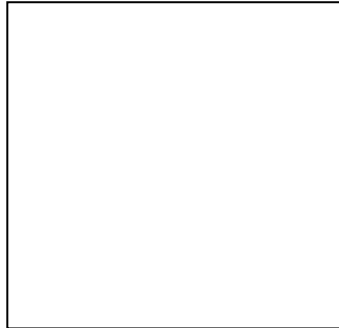
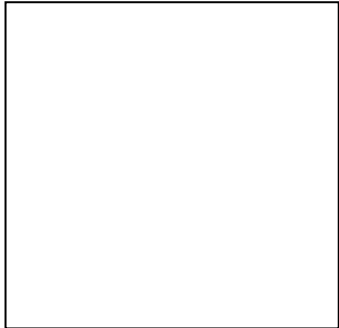

HEX

RANGE

(ATEX)

2013

**MOTOCOMPRESSORI SEMIHERMETICI
SEMI-HERMETIC MOTOR-COMPRESSORS
MOTO-COMPRESSEURS SEMI-HERMETIQUES
HALBHERMETISCHE VERDICHTER**

I motocompressori della serie HEX sono macchine progettate in accordo ai requisiti di sicurezza previsti per l'uso in zona classificata per presenza di gas infiammabili (zona 2, gruppo di gas IIB) secondo la Direttiva ATEX 94/9/CE e utilizzano componenti elettrici conformi alla Direttiva ATEX 94/9/CE (escluso INT69 e CPM3).

La gamma copre volumi spostati da 2.89 a 244.78 m³/h, con potenze elettriche nominali da 0.5 a 90 hp.

Le principali caratteristiche della gamma presentata sono:

- elevati valori di C.O.P., ottenuti grazie all'ottimizzazione fluidodinamica dei passaggi interni, all'adozione di motori ad alta efficienza ed all'introduzione di componentistica di ultima generazione
- possibilità di funzionamento con tutti i refrigeranti più diffusi sul mercato: HC (R290 e R1270) e HFC (R404A, R134a, R407C, R507)
- livelli di rumorosità estremamente contenuti
- scatola attacchi elettrici IP 65 di serie sulla totalità della gamma
- sensore PTC per il controllo della temperatura di mandata di serie sulla totalità della gamma
- spia olio speciale (esclusa la gamma HEX1)
- olio minerale ad elevata viscosità (68) nel caso di HC (R290 e R1270) e olio POE nel caso di HFC (R404A, R134a, R407C, R507)
- teste speciali per le serie HEX1, HEX2, HEX32, HEX35 e HEX41
- sensore differenziale di pressione olio (di serie sulle gamme HEX5, HEX6 e HEX7) e resistenza carter (di serie sulla totalità della gamma) di categoria 3G, modo di protezione Ex nA
- accessori del compressore (bobina parzializzazione per regolazione di potenza e per partenza a vuoto) di categoria 3G, modo di protezione Ex nA

Compressors belonging to HEX range are designed according to the safety requirements imposed for the use in flammable risky areas (zone 2, gas group IIB), as defined in ATEX 94/9/CE, featuring electric component conforming to such directive (exception made for INT69 and CPM3).

The range covers displacements from 2.89 to 244.78 m³/h and nominal capacities from 0.5 to 90 hp.

The main characteristics of our compressors are:

- high C.O.P. values, thanks to fluidodynamic optimization of the internal flow paths, to high efficiency motors and high tech components
- suitable for all the main refrigerants available: HC (R290 and R1270) and HFC (R404A, R134a, R407C, R507)
- very low noise level
- available on request for frequency variations
- standard electrical box IP65
- PTC sensor for discharge temperature control standard for the entire range
- special oil sight glass (exception made for HEX1)
- mineral oil with high viscosity (68) for HC (R290 and R1270) and POE for HFC (R404A, R134a, R407C, R507)
- special heads for ranges HEX1, HEX2, HEX32, HEX35 and HEX41
- Special oil differential pressure sensor (standard for HEX5, HEX6 and HEX7) and crankcase heater (standard for entire range), category 3G, protection rating Ex nA
- special accessories, category 3G, protection rating Ex nA applying to crankcase heater, coils for capacity regulation and unloaded start

Les moto-compresseurs de la série HEX sont des machines envisagées suivant les conditions de sécurité requises pour l'emploi dans une zone classée pour la présence de gaz inflammables (zone 2, groupe de gaz IIB) selon la Directive ATEX 94/9/CE et ils utilisent des composants électriques conformes à la Directive ATEX 94/9/CE (INT69 et CPM3 excepté).

La gamme couvre des volumes déplacés entre 2.89 et 244.78 m³/h, avec des puissances électriques nominales de 0.5 à 90 hp.

Les caractéristiques principales de la gamme présentée sont les suivantes:

- des valeurs C.O.P. élevées obtenues grâce à l'optimisation fluidodynamique des pièces internes, aux moteurs à haute efficacité et à l'introduction de composants électroniques de dernière génération
- la possibilité de fonctionnement avec tous les réfrigérants les plus répandus sur le marché: HC (R290 et R1270) et HFC (R404A, R134a, R407C, R507)
- des niveaux de bruit extrêmement contenus
- un boîtier de prises électriques IP 65 de série sur la totalité de la gamme
- capteur PTC pour le contrôle de la température de refoulement de série sur la totalité de la gamme
- voyant de l'huile spécial (excepté la gamme HEX1)
- huile minerale à viscosité élevée (68) pour HC (R290 et R1270) et POE pour HFC (R404A, R134a, R407C, R507)
- têtes spéciales pour les séries HEX1, HEX2, HEX32, HEX35 et HEX41
- capteur différentiel de pression huile (de série sur les gammes HEX5, HEX6 et HEX7) et résistance carter (de série sur la totalité de la gamme) de catégorie 3G, mode de protection Ex nA
- accessoires du compresseur (bobine réglage pour régler la puissance et pour démarrage vide) de catégorie 3G, mode de protection Ex nA

Die Verdichter der HEX Reihe wurden speziell für riskante und entflammbare Umgebungen (Zone 2, Gasgruppe IIB nach Definition ATEX 94/9/CE) entwickelt, welche alle elektrische Komponenten beinhaltet (Ausnahme INT69 und CPM3).

Die Baureihe deckt Fördermengen von 2.89 bis 244.78 m³/h und Nennleistungen von 0.5 PS bis 90 PS ab.

Wichtige Merkmale der vorgestellten Baureihe sind:

- Hohe Leistungszahl (COP) dank der Optimierung der Strömungsdynamik der internen Medienleitungen, der Verwendung von Hochleistungsmotoren und der Verwendung von Komponenten der neuesten Generation
- Betrieb mit allen markt gängigen Kältemitteln möglich: HC (R290 und R1270) und HFC (R404A, R134a, R407C, R507)
- Extrem geringe Geräuschentwicklung
- Auf Anfrage auch für Invertersteuerung verfügbar
- Verringerung von Gasdruckschwankungen
- Anschlusskasten in IP 65 bei fast allen Modellen der Baureihe serienmäßig
- PTC Fühler für Heisgastemperatur-Messung
- Spezielles Ölschauglas
- Mineralöl mit einer Viskosität von 68 wenn verwendet HC (R290 und R1270) und POE wenn verwendet HFC (R404A, R134a, R407C, R507)
- Spezielle Köpfe für HEX1, HEX2, HEX32, HEX35 und HEX41
- Spezieller Öldifferenzdruckschalter (Standard für HEX5, HEX6 und HEX7) und Ölumpfheizung (Standard für das gesamte Sortiment), der Kategorie 3G (Ex nA) verfügbar
- Spezielles Zubehör nach Kategorie 3G (Ex nA) verfügbar

Sul motocompressore è riportata la seguente marcatura ATEX:

Each compressor shows following ATEX marking:

Le marquage ATEX suivant est indiqué sur le motocompresseur :

Jeder Kompressor hat folgende ATEX-Kennzeichnung:



II = apparecchio del gruppo II
3 = categoria 3 (zona 2)
G = atmosfera esplosiva con presenza di gas, vapori o nebbie
c = modo di protezione apparecchiature non elettriche (sicurezza costruttiva)
IIB = gruppo di gas
T3 = classe di temperatura (gas)

Prima dell'installazione leggere attentamente quanto riportato nelle istruzioni d'uso.

Nel presente catalogo sono riportati soltanto i diagrammi di applicazione e le prestazioni (dati provvisori calcolati) dei refrigeranti HC, propano (R290) e propilene (R1270). Per i dati relativi ai refrigeranti HFC riferirsi al catalogo dei compressori semiermetici serie H.

Per individuare gli esatti limiti di funzionamento di ogni singolo modello riferirsi al software di selezione Dorin.

La qualità dell'intera produzione Dorin è garantita dalla conformità alle norme EN ISO9001.

II = group II machinery
3 = category 3 (zone 2)
G = explosive atmosphere with gas, vapor or fog presence
c = protection type for non-electric equipment (constructive safety)
IIB = gas group
T3 = temperature class (gas)

It is mandatory to carefully read instruction manual before compressor installation and equipment commissioning.

This catalogue displays only calculated performance and application envelopes for HC refrigerants, e.g. propane (R290) and propylene (R1270). For HFC performance, please refer to H range compressor catalogue. In order to define the exact operating limits for each model, refer to Dorin selection software.

Dorin's manufacturing quality is granted by the certification provided in accordance with Directive EN ISO9001.

II = dispositif du groupe II
3 = catégorie 3 (zone 2)
G = atmosphère explosive à la présence de gaz, de vapeurs ou de brouillards
c = mode de protection appareillages non électriques (sécurité constructive)
IIB = groupe de gaz
T3 = classe de température (gaz)

Il faut lire attentivement le mode d'emploi avant l'installation.

Ce catalogue n'indique que les diagrammes d'application et les performances (données provisoires calculées) des réfrigérants HC, propane (R290) et propylène (R1270). Pour les données concernant les réfrigérants HFC se référer au catalogue des compresseurs semi-hermétiques série H. Afin de déterminer les limites exactes de fonctionnement de chaque modèle voir le logiciel de sélection Dorin.

La qualité de toute la production Dorin est garantie par la conformité aux règles EN ISO9001.

II = Maschine der Gruppe 2
3 = Kategorie 3 (Zone2)
G = explosive Umgebung, für Gase und Stäube
c = Sicherheitsklasse für nichtelektronische Ausrüstung
IIB = Gas Gruppe
T3 = Temperatur Klasse

Die Anleitung für den Verdichter und das Equipment ist vor der Installation gründlich zu lesen.

Die Informationen in diesem Katalog basieren auf Leistungs- Kalkulationen für HC Kältemittel. (wie R290 und R1270) Für HFC Leistungen schlagen Sie bitte im H – Range Katalog nach.

Für eine genaue Abgrenzung des Arbeitsbereiches der Verdichter benutzen Sie bitte die Selection Software von Dorin.

Die Qualität aller Dorin Produkte ist gewährleistet durch ein zertifiziertes Qualitätsmanagement nach DIN ISO 9001.

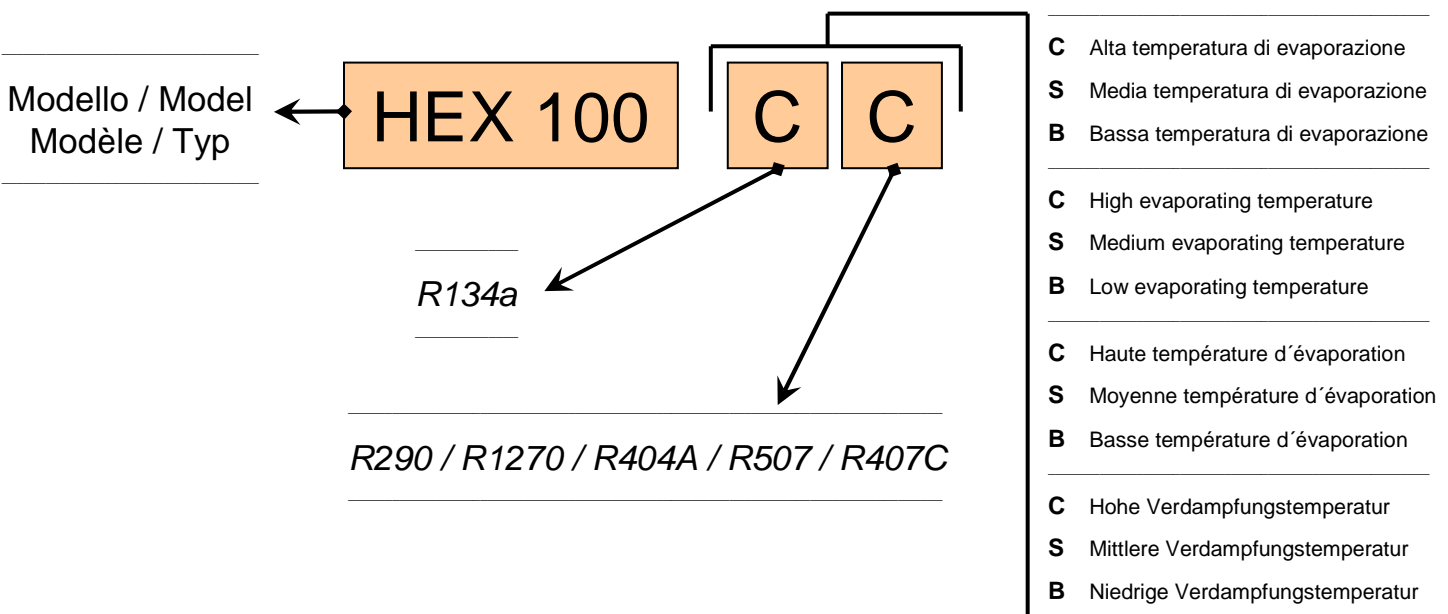

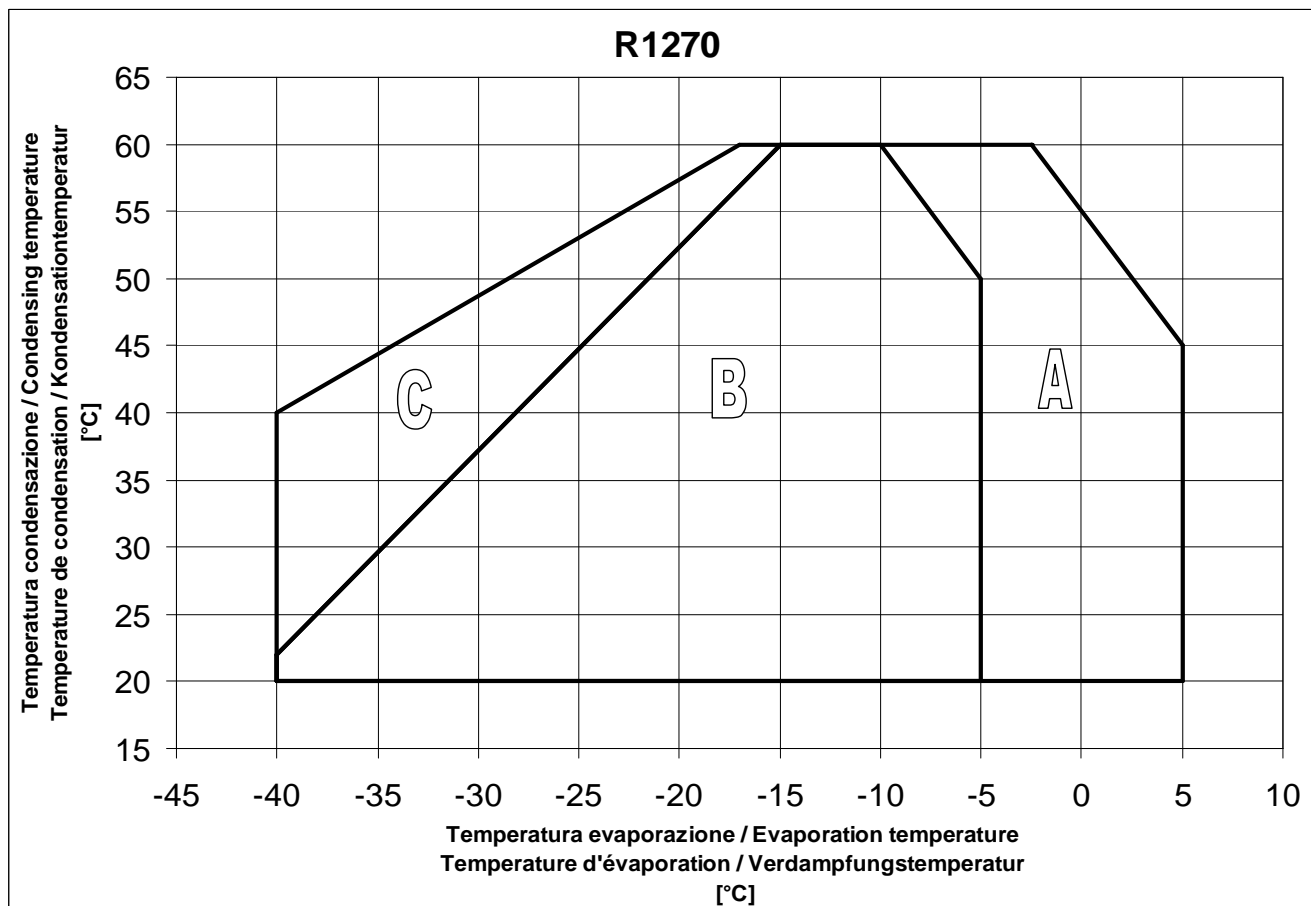
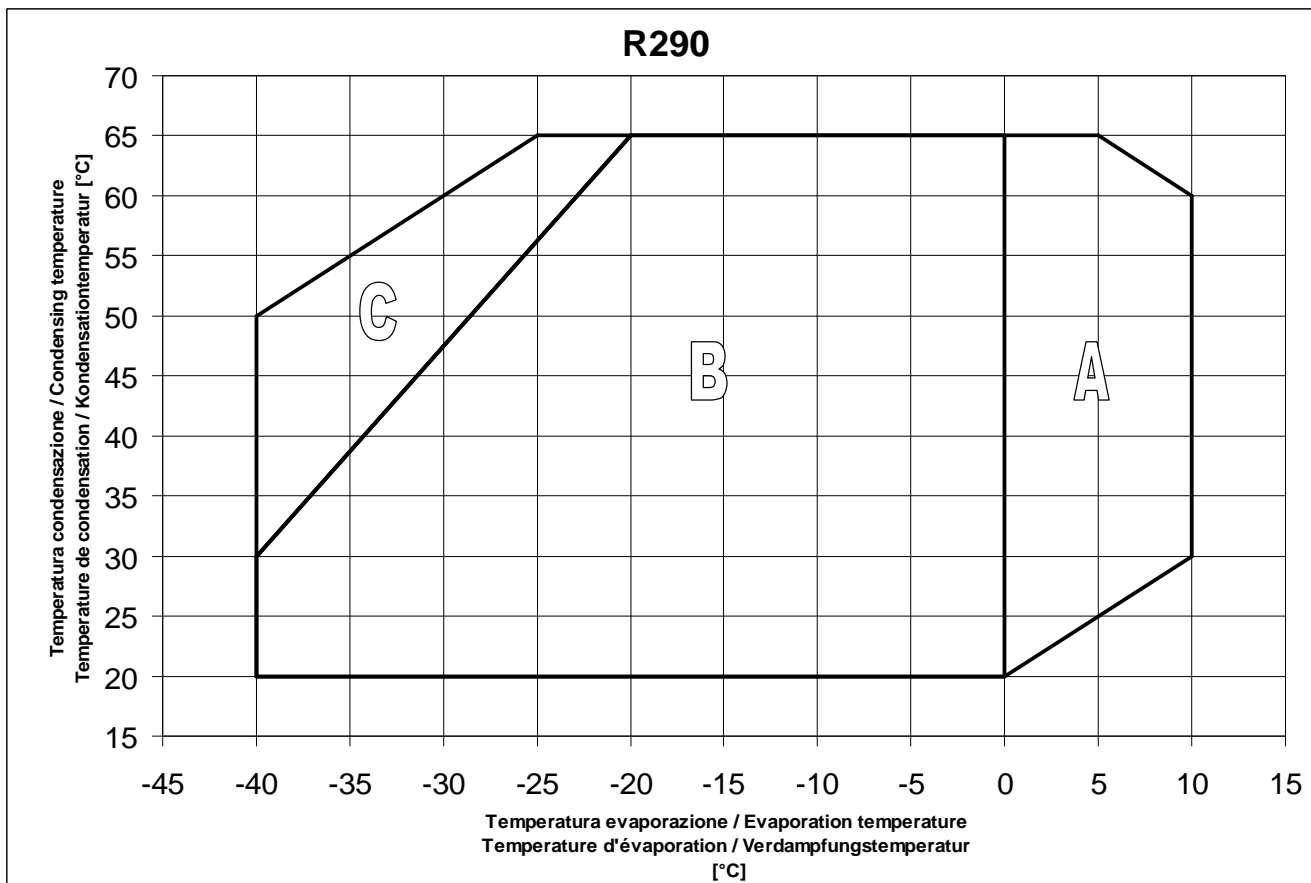

- A** Solo per modelli "CC" / "CC" models only / Uniquement modèles "CC" / Nur "CC" Modelle
- B** Applicazione standard / Normal operation / Application standard / Standard Einsatz
- C** Surriscaldamento massimo gas aspirato 20K / Max suction gas superheat 20K / Max surchauffe du gaz aspiré 20K / Max Sauggas-Überhitzung 20K

Serie Range Serie Serie	Modello Model Modèle Typ	Vol. Spost. Displacement Volume bal. Fördervolumen	Campo d'applicazione Application range Champs d'application Einsatzbereich		
			[m ³ /h]	R290 R1270	R404A / R507 R407C
HEX1	HEX40CC	2,89	H	H	H
	HEX50CS	3,86	M	M	H
	HEX75CC	3,86	H	H	H
	HEX75CS	5,30	M	M	H
	HEX100CC	5,30	H	H	H
	HEX100CS	6,75	M	M	H
	HEX150CC	6,75	H	H	H
	HEX150CS	7,71	M	M	H
	HEX180CC	7,71	H	H	H
	HEX180CS	8,47	M	M	H
	HEX200CC	8,47	H	H	H
	HEX200CS	9,88	M	M	H
	HEX220CC	9,88	H	H	H
	HEX220CS	10,85	M	M	H
	HEX250CC	10,85	H	H	H
	HEX250CS	12,17	M	M	H
	HEX280CC	12,17	H	H	H
	HEX280SB	13,23	M	M	H
HEX280CS	13,23	M	M	H	
HEX2	HEX290CS	14,74	M	M	H
	HEX300CC	14,74	H	H	H
	HEX300CS	15,94	M	M	H
	HEX350CC	15,94	H	H	H
	HEX350SB	17,53	L	L	H
	HEX380CC	17,53	H	H	H
	HEX380SB	19,53	L	L	H
	HEX390CS	19,53	M	M	H
	HEX392CS	23,31	L	L	H
HEX32	HEX403CC	19,98	H	H	H
	HEX403CS	22,83	M	M	H
	HEX503CC	22,83	H	H	H
	HEX503CS	26,44	M	M	H
	HEX743CC	26,44	H	H	H
HEX35	HEX401CS	19,29	M	M	H
	HEX451CC	19,29	H	H	H
	HEX451CS	23,13	M	M	H
	HEX551CC	23,13	H	H	H
	HEX551CS	27,33	M	M	H
	HEX701CC	27,33	H	H	H
	HEX701CS	31,88	M	M	H
	HEX751CC	31,88	H	H	H
	HEX751CS	38,06	M	M	H
	HEX1002CC	38,06	H	H	H
	HEX801CS	43,73	M	M	H
	HEX1003CC	43,73	H	H	H
HEX41	HEX851CS	42,81	M	M	H
	HEX1201CC	42,81	H	H	H
	HEX1001CS	48,82	M	M	H
	HEX1501CC	48,82	H	H	H
	HEX1501CS	56,87	M	M	H
	HEX2001CC	56,87	H	H	H
	HEX1601CS	63,76	M	M	H
HEX2201CC	63,76	H	H	H	

Serie Range Serie Serie	Modello Model Modèle Typ	Vol. Spost. Displacement Volume bal. Fördervolumen	Campo d'applicazione Application range Champs d'application Einsatzbereich		
			[m ³ /h]	R290 R1270	R404A / R507 R407C
HEX5	HEX2000CS	75,83	M	M	H
	HEX2500CC	75,83	H	H	H
	HEX2500CS	85,01	M	M	H
	HEX3000CC	85,01	H	H	H
	HEX2700CS	92,25	M	M	H
	HEX3200CC	92,25	H	H	H
	HEX2900CS	102,35	M	M	H
	HEX3400CC	102,35	H	H	H
HEX6	HEX3000CS	113,74	M	M	H
	HEX3500CC	113,74	H	H	H
	HEX3500CS	127,52	M	M	H
	HEX4000CC	127,52	H	H	H
	HEX4000CS	138,37	M	M	H
	HEX4500CC	138,37	H	H	H
	HEX4500CS	153,52	M	M	H
	HEX5000CC	153,52	H	H	H
HEX7	HEX5000CS	164,30	M	M	H
	HEX5500CC	164,30	H	H	H
	HEX5500CS	184,19	M	M	H
	HEX6000CC	184,19	H	H	H
	HEX6000CS	199,86	M	M	H
	HEX7500CC	199,86	H	H	H
	HEX7501CS	221,75	M	M	H
	HEX8001CC	221,75	H	H	H
HEX8000CS	244,78	M	M	H	
HEX9000CC	244,78	H	H	H	

H Alta temperatura di evaporazione fino a +5 °C/+10 °C

M Media temperatura di evaporazione fino a -5 °C

L Bassa temperatura di evaporazione fino a -20 °C

H High evaporating temperature up to +5 °C/+10 °C

M Medium evaporating temperature up to -5 °C

L Low evaporating temperature up to -20 °C

H Haute température d'évaporation jusqu'à +5 °C/+10 °C

M Moyenne température d'évaporation jusqu'à -5 °C

L Basse température d'évaporation jusqu'à -20 °C

H Hohe Verdampfungstemperatur bis zu +5 °C/+10 °C

M Mittlere Verdampfungstemperatur bis -5 °C

L Niedrige Verdampfungstemperatur bis -20 °C

Serie Range Serie	Modello Model Modèle Typ	Carica olio Oil charge Charge huile Ölfüllung	Aspirazione Suction Aspiration Saugventil	Scarico Discharge Refolement Druckventil	Peso netto Net weight Poids net Nettogewicht
		[kg]	SL [mm]	DL [mm]	[kg]
HEX1	HEX40CC	1,0	12s	12s	35
	HEX50CS	1,0	12s	12s	35
	HEX75CC	1,0	12s	12s	36
	HEX75CS	1,0	16s	12s	36
	HEX100CC	1,0	16s	12s	37
	HEX100CS	1,0	16s	12s	37
	HEX150CC	1,0	16s	12s	38
	HEX150CS	1,0	16s	12s	38
	HEX180CC	1,0	16s	12s	39
	HEX180CS	1,0	16s	12s	39
	HEX200CC	1,0	16s	12s	40
	HEX200CS	1,0	18s	16s	40
	HEX220CC	1,0	18s	16s	41
	HEX220CS	1,0	18s	16s	41
	HEX250CC	1,0	18s	16s	41
	HEX250CS	1,0	18s	16s	41
	HEX280CC	1,0	18s	16s	43
	HEX280SB	1,0	18s	16s	44
HEX280CS	1,0	18s	16s	44	
HEX2	HEX290CS	1,4	22s	16s	54
	HEX300CC	1,4	22s	16s	54
	HEX300CS	1,4	28s	16s	54
	HEX350CC	1,4	28s	16s	54
	HEX350SB	1,4	28s	16s	54
	HEX380CC	1,4	28s	16s	56
	HEX380SB	1,4	28s	16s	56
	HEX390CS	1,4	28s	16s	56
HEX392CS	1,4	28s	16s	56	
HEX32	HEX403CC	2,0	28s	16s	75
	HEX403CS	2,0	28s	16s	76
	HEX503CC	2,0	28s	16s	79
	HEX503CS	2,0	35s	16s	80
	HEX743CC	2,0	35s	16s	81
HEX35	H401CS	2,0	22s	18s	89
	H451CC	2,0	22s	18s	91
	H451CS	2,0	28s	18s	89
	H551CC	2,0	28s	18s	91
	H551CS	2,0	28s	22s	91
	H701CC	2,0	28s	22s	91
	H701CS	2,0	28s	22s	91
	H751CC	2,0	28s	22s	91
	H751CS	2,0	35s	22s	91
	HEX1002CC	2,0	35s	22s	101
	HEX801CS	2,0	35s	22s	91
HEX1003CC	2,0	35s	22s	101	
HEX41	H851CS	2,5	35s	28s	125
	H1201CC	2,5	35s	28s	130
	H1001CS	2,5	35s	28s	127
	H1501CC	2,5	42s	28s	131
	H1501CS	2,5	35s	28s	127
	H2001CC	2,5	42s	28s	131
	H1601CS	2,5	42s	28s	134
H2201CC	2,5	42s	28s	136	

Serie Range Serie	Modello Model Modèle Typ	Carica olio Oil charge Charge huile Ölfüllung	Aspirazione Suction Aspiration Saugventil	Scarico Discharge Refolement Druckventil	Peso netto Net weight Poids net Nettogewicht
		[kg]	SL [mm]	DL [mm]	[kg]
HEX5	HEX2000CS	3,5	42s	28s	190
	HEX2500CC	3,5	54s	28s	185
	HEX2500CS	3,5	54s	28s	185
	HEX3000CC	3,5	54s	28s	199
	HEX2700CS	3,5	54s	35s	200
	HEX3200CC	3,5	54s	35s	205
	HEX2900CS	3,5	54s	35s	205
	HEX3400CC	3,5	54s	35s	205
HEX6	HEX3000CS	3,5	54s	35s	235
	HEX3500CC	3,5	54s	35s	246
	HEX3500CS	3,5	54s	35s	233
	HEX4000CC	3,5	54s	35s	249
	HEX4000CS	3,5	54s	42s	244
	HEX4500CC	3,5	54s	42s	252
	HEX4500CS	3,5	54s	42s	253
	HEX5000CC	3,5	54s	42s	253
HEX7	HEX5000CS	8,5	66s	42s	350
	HEX5500CC	8,5	66s	42s	355
	HEX5500CS	8,5	80s	42s	350
	HEX6000CC	8,5	80s	42s	355
	HEX6000CS	8,5	80s	42s	355
	HEX7500CC	8,5	80s	42s	357
	HEX7501CS	8,5	80s	54s	355
	HEX8001CC	8,5	80s	54s	357
	HEX8000CS	8,5	80s	54s	360
	HEX9000CC	8,5	80s	54s	366

Serie Range Serie Serie	Modello Model Modèle Typ	Vol. Spost. Displacement Volume bal. Fördervolumen		Max corrente di funzionamento / Max operating current Max intensité de fonctionnement / Max Betriebsstrom V / ph / Hz [A]												
		50 Hz [m ³ /h]	60 Hz [m ³ /h]	220-240 / 1 / 50	208-230 / 1 / 60	115 / 1 / 60	220-240 / 3 / 50 265-290 / 3 / 60 Δ	380-420 / 3 / 50 440-480 / 3 / 60 Y	208-230 / 3 / 60 Δ	360-400 / 3 / 60 Y	200 / 3 / 50-60 Δ	380-420 / 3 / 50 440-480 / 3 / 60 PWS	220-240 / 3 / 50 PWS	208-230 / 3 / 60 PWS	360-400 / 3 / 60 PWS	500-550 / 3 / 50
HEX41	HEX851CS	42,81	51,38	-	-	-	34,5	20,0	41,5	24,0	-	20,0	34,5	41,5	24,0	14,5
	HEX1201CC	42,81	51,38	-	-	-	48,5	28,0	58	33,5	-	28,0	48,5	58	33,5	14,5
	HEX1001CS	48,82	58,58	-	-	-	41,5	24,0	50	29,0	-	24,0	41,5	50	29,0	14,5
	HEX1501CC	48,82	58,58	-	-	-	59	34,0	71	41,0	-	34,0	59	71	41,0	26,0
	HEX1501CS	56,87	68,25	-	-	-	48,5	28,0	58	33,5	-	28,0	48,5	58	33,5	14,5
	HEX2001CC	56,87	68,25	-	-	-	66	38,0	79	45,5	-	38,0	66	79	45,5	29,0
	HEX1601CS	63,76	76,51	-	-	-	59	34,0	71	41,0	-	34,0	59	71	41,0	26,0
HEX2201CC	63,76	76,51	-	-	-	78	45,0	93	54	-	45,0	78	93	54	34,5	
HEX5	HEX2000CS	75,83	91,00	-	-	-	66	38,0	79	45,5	-	38,0	66	79	45,5	-
	HEX2500CC	75,83	91,00	-	-	-	83	48,0	100	58	-	48,0	83	100	58	-
	HEX2500CS	85,01	102,02	-	-	-	78	45,0	93	54	-	45,0	78	93	54	-
	HEX3000CC	85,01	102,02	-	-	-	97	56	116	67	-	56	97	116	67	-
	HEX2700CS	92,25	110,69	-	-	-	83	48,0	100	58	-	48,0	83	100	58	-
	HEX3200CC	92,25	110,69	-	-	-	104	60	125	72	-	60	104	125	72	-
	HEX2900CS	102,35	122,82	-	-	-	97	56	116	67	-	56	97	116	67	-
HEX3400CC	102,35	122,82	-	-	-	104	60	125	72	-	60	104	125	72	-	
HEX6	HEX3000CS	113,74	136,49	-	-	-	104	60	125	72	-	60	104	125	72	-
	HEX3500CC	113,74	136,49	-	-	-	114	66	137	79	-	66	114	137	79	-
	HEX3500CS	127,52	153,02	-	-	-	104	60	125	72	-	60	104	125	72	-
	HEX4000CC	127,52	153,02	-	-	-	130	75	156	90	-	75	130	156	90	-
	HEX4000CS	138,37	166,04	-	-	-	114	66	137	79	-	66	114	137	79	-
	HEX4500CC	138,37	166,04	-	-	-	145	84	175	101	-	84	145	175	101	-
	HEX4500CS	153,52	184,22	-	-	-	130	75	156	90	-	75	130	156	90	-
HEX5000CC	153,52	184,22	-	-	-	161	93	193	112	-	93	161	193	112	-	
HEX7	HEX5000CS	164,30	197,16	-	-	-	156	90	187	108	-	90	156	187	108	-
	HEX5500CC	164,30	197,16	-	-	-	182	105	218	126	-	105	182	218	126	-
	HEX5500CS	184,19	221,03	-	-	-	182	105	218	126	-	105	182	218	126	-
	HEX6000CC	184,19	221,03	-	-	-	208	120	249	144	-	120	208	249	144	-
	HEX6000CS	199,86	239,83	-	-	-	182	105	218	126	-	105	182	218	126	-
	HEX7500CC	199,86	239,83	-	-	-	256	148	308	178	-	148	256	308	178	-
	HEX7501CS	221,75	266,10	-	-	-	208	120	249	144	-	120	208	249	144	-
	HEX8001CC	221,75	266,10	-	-	-	256	148	308	178	-	148	256	308	178	-
HEX8000CS	244,78	293,74	-	-	-	208	120	249	144	-	120	208	249	144	-	
HEX9000CC	244,78	293,74	-	-	-	256	148	308	178	-	148	256	308	178	-	

- Versione del motore standard. Per condizioni di funzionamento non indicate contattare il nostro servizio tecnico.
- Standard motor version. For operating conditions not indicated please contact our technical service.
- Standard version du moteur. Pour les conditions de fonctionnement pas indiquées contacter notre service technique.
- Standard Motor Version. Für Betriebsbedingungen, die hier nicht aufgeführt sind wenden Sie sich bitte an unseren Technischen Dienst.

Serie Range Serie Serie	Modello Model Modèle Typ	Vol. Spost. Displacement Volume bal. Fördervolumen		Corrente a rotore bloccato / Locked rotor current / Courant a rotor bloqué / Anlaufstrom V / ph / Hz [A]												
		50 Hz [m ³ /h]	60 Hz [m ³ /h]	220-240 / 1 / 50	208-230 / 1 / 60	115 / 1 / 60	220-240 / 3 / 50 265-290 / 3 / 60 Δ	380-420 / 3 / 50 440-480 / 3 / 60 Y	208-230 / 3 / 60 Δ	360-400 / 3 / 60 Y	200 / 3 / 50-60 Δ	380-420 / 3 / 50 440-480 / 3 / 60 PWS *	220-240 / 3 / 50 PWS *	208-230 / 3 / 60 PWS *	360-400 / 3 / 60 PWS *	500-550 / 3 / 50
HEX41	HEX851CS	42,81	51,38	-	-	-	181	105	217	126	-	105	181	217	126	80
	HEX1201CC	42,81	51,38	-	-	-	233	135	280	162	-	135	233	280	162	103
	HEX1001CS	48,82	58,58	-	-	-	188	109	226	130	-	109	188	226	130	83
	HEX1501CC	48,82	58,58	-	-	-	295	171	354	205	-	171	295	354	205	130
	HEX1501CS	56,87	68,25	-	-	-	233	135	280	162	-	135	233	280	162	103
	HEX2001CC	56,87	68,25	-	-	-	306	177	367	212	-	177	306	367	212	135
	HEX1601CS	63,76	76,51	-	-	-	295	171	354	205	-	171	295	354	205	130
HEX2201CC	63,76	76,51	-	-	-	351	203	421	244	-	203	351	421	244	155	
HEX5	HEX2000CS	75,83	91,00	-	-	-	306	177	367	212	-	177	306	367	212	-
	HEX2500CC	75,83	91,00	-	-	-	351	203	421	244	-	203	351	421	244	-
	HEX2500CS	85,01	102,02	-	-	-	351	203	421	244	-	203	351	421	244	-
	HEX3000CC	85,01	102,02	-	-	-	388	224	465	269	-	224	388	465	269	-
	HEX2700CS	92,25	110,69	-	-	-	351	203	421	244	-	203	351	421	244	-
	HEX3200CC	92,25	110,69	-	-	-	450	260	540	312	-	260	450	540	312	-
	HEX2900CS	102,35	122,82	-	-	-	388	224	465	269	-	224	388	465	269	-
HEX3400CC	102,35	122,82	-	-	-	450	260	540	312	-	260	450	540	312	-	
HEX6	HEX3000CS	113,74	136,49	-	-	-	388	224	465	269	-	224	388	465	269	-
	HEX3500CC	113,74	136,49	-	-	-	450	260	540	312	-	260	450	540	312	-
	HEX3500CS	127,52	153,02	-	-	-	388	224	465	269	-	224	388	465	269	-
	HEX4000CC	127,52	153,02	-	-	-	502	290	602	348	-	290	502	602	348	-
	HEX4000CS	138,37	166,04	-	-	-	450	260	540	312	-	260	450	540	312	-
	HEX4500CC	138,37	166,04	-	-	-	559	323	671	388	-	323	559	671	388	-
	HEX4500CS	153,52	184,22	-	-	-	502	290	602	348	-	290	502	602	348	-
HEX5000CC	153,52	184,22	-	-	-	619	358	743	430	-	358	619	743	430	-	
HEX7	HEX5000CS	164,30	197,16	-	-	-	636	367	763	440	-	367	636	763	440	-
	HEX5500CC	164,30	197,16	-	-	-	788	455	946	546	-	455	788	946	546	-
	HEX5500CS	184,19	221,03	-	-	-	788	455	946	546	-	455	788	946	546	-
	HEX6000CC	184,19	221,03	-	-	-	942	544	1131	653	-	544	942	1131	653	-
	HEX6000CS	199,86	239,83	-	-	-	788	455	946	546	-	455	788	946	546	-
	HEX7500CC	199,86	239,83	-	-	-	1012	584	1214	701	-	584	1012	1214	701	-
	HEX7501CS	221,75	266,10	-	-	-	942	544	1131	653	-	544	942	1131	653	-
	HEX8001CC	221,75	266,10	-	-	-	1012	584	1214	701	-	584	1012	1214	701	-
	HEX8000CS	244,78	293,74	-	-	-	942	544	1131	653	-	544	942	1131	653	-
HEX9000CC	244,78	293,74	-	-	-	1012	584	1214	701	-	584	1012	1214	701	-	

Versione del motore standard. Per condizioni di funzionamento non indicate contattare il nostro servizio tecnico.

* Il valore di corrente indicato si riferisce al collegamento diretto. Per ottenere il valore con collegamento PWS consultare il bollettino tecnico.

Standard motor version. For operating conditions not indicated please contact our technical service.

* The current value indicated refers to the direct connection. For the value with PWS connecting see technical bulletin.

Standard version du moteur. Pour les conditions de fonctionnement pas indiquées contacter notre service technique.

* La valeur de courant indiquée se réfère à la connexion directe. Pour obtenir la valeur avec connexions PWS voir le Bulletin technique.

Standard Motor Version. Für Betriebsbedingungen, die hier nicht aufgeführt sind wenden Sie sich bitte an unseren Technischen Dienst.

* Der angegebene Wert bezieht sich auf direkten Anschluss. Um den Wert der PWS-Verbindung siehe Technical Bulletin.



Serie Range Serie Serie	Modello Model Modèle Typ	Temp. Cond. Cond. Temp. Temp. Cond. Kond. Temp.	[°C]	Q [W]	Capacità frigorifera Refrigerating capacity Puissance frigorifique Kälteleistung					P [kW]	Potenza assorbita Power input Puissance absorbée Leistungsaufnahme				
					Temperatura evaporazione / Evaporating temperature Température d'évaporation / Verdampfungstemperatur [°C]										
					+10	+5	0	-5	-10		-15	-20	-25	-30	-35
HEX35	HEX551CC	30	Q	25460	21690	18320	15350	12720	10440	8440	6720	5250	4000	2930	
			P	3,58	3,65	3,66	3,61	3,51	3,36	3,16	2,91	2,63	2,32	1,98	
		40	Q	22390	18990	15980	13310	10970	8940	7160	5640	4330	3210	2240	
			P	4,36	4,33	4,25	4,10	3,91	3,67	3,39	3,07	2,71	2,33	1,92	
		50	Q	19340	16320	13660	11310	9260	7470	5920	4590	3440	2450	1580	
			P	4,98	4,86	4,69	4,47	4,19	3,88	3,52	3,13	2,70	2,25	1,78	
	HEX551CS	30	Q	-	-	21650	18130	15030	12320	9960	7930	6190	4710	3450	
			P	-	-	4,33	4,27	4,15	3,96	3,73	3,44	3,11	2,74	2,34	
		40	Q	-	-	18870	15720	12960	10550	8460	6660	5110	3780	2640	
			P	-	-	5,02	4,85	4,62	4,34	4,00	3,63	3,21	2,75	2,26	
		50	Q	-	-	16130	13350	10930	8820	6990	5410	4060	2880	1860	
			P	-	-	5,54	5,28	4,95	4,58	4,16	3,69	3,19	2,66	2,10	
	HEX701CC	30	Q	30080	25620	21650	18130	15030	12320	9960	7930	6190	4710	3450	
			P	4,23	4,32	4,33	4,27	4,15	3,96	3,73	3,44	3,11	2,74	2,34	
		40	Q	26450	22430	18870	15720	12960	10550	8460	6660	5110	3780	2640	
			P	5,15	5,12	5,02	4,85	4,62	4,34	4,00	3,63	3,21	2,75	2,26	
		50	Q	22850	19280	16130	13350	10930	8820	6990	5410	4060	2880	1860	
			P	5,88	5,75	5,54	5,28	4,95	4,58	4,16	3,69	3,19	2,66	2,10	
	HEX701CS	30	Q	-	-	25250	21140	17530	14370	11620	9250	7220	5500	4030	
			P	-	-	5,05	4,98	4,84	4,62	4,35	4,02	3,63	3,20	2,73	
		40	Q	-	-	22010	18340	15120	12310	9870	7760	5960	4410	3080	
			P	-	-	5,85	5,66	5,39	5,06	4,67	4,23	3,74	3,21	2,64	
		50	Q	-	-	18810	15580	12750	10290	8150	6320	4730	3360	2170	
			P	-	-	6,47	6,15	5,78	5,34	4,85	4,31	3,73	3,11	2,45	
	HEX751CC	30	Q	35090	29890	25260	21150	17530	14380	11630	9260	7220	5500	4030	
			P	4,93	5,03	5,05	4,98	4,84	4,62	4,35	4,02	3,63	3,20	2,73	
		40	Q	30860	26170	22020	18340	15120	12310	9870	7770	5960	4420	3080	
			P	6,01	5,97	5,85	5,66	5,39	5,06	4,67	4,23	3,74	3,21	2,64	
		50	Q	26660	22490	18820	15580	12750	10290	8160	6320	4740	3370	2180	
			P	6,86	6,70	6,47	6,15	5,78	5,34	4,85	4,31	3,73	3,11	2,45	
	HEX751CS	30	Q	-	-	30170	25260	20940	17160	13890	11060	8630	6570	4820	
			P	-	-	6,03	5,95	5,78	5,52	5,19	4,80	4,34	3,82	3,26	
		40	Q	-	-	26290	21910	18060	14710	11790	9280	7120	5270	3690	
			P	-	-	6,99	6,76	6,44	6,04	5,58	5,05	4,47	3,83	3,15	
		50	Q	-	-	22480	18610	15230	12290	9740	7550	5660	4010	2590	
			P	-	-	7,72	7,35	6,90	6,38	5,79	5,15	4,45	3,71	2,93	
	HEX1002CC	30	Q	41910	35700	30170	25260	20940	17160	13890	11060	8630	6570	4820	
			P	5,89	6,01	6,03	5,95	5,78	5,52	5,19	4,80	4,34	3,82	3,26	
		40	Q	36850	31260	26290	21910	18060	14710	11790	9280	7120	5270	3690	
			P	7,17	7,13	6,99	6,76	6,44	6,04	5,58	5,05	4,47	3,83	3,15	
		50	Q	31840	26860	22480	18610	15230	12290	9740	7550	5660	4010	2590	
			P	8,20	8,01	7,72	7,35	6,90	6,38	5,79	5,15	4,45	3,71	2,93	
	HEX801CS	30	Q	-	-	34318	28733	23819	19519	15800	12581	9817	7473	5483	
			P	-	-	6,86	6,77	6,57	6,28	5,91	5,46	4,93	4,35	3,71	
		40	Q	-	-	29904	24922	20543	16732	13411	10556	8099	5995	4197	
			P	-	-	7,95	7,69	7,32	6,88	6,35	5,75	5,08	4,36	3,59	
		50	Q	-	-	25571	21169	17324	13980	11079	8588	6438	4561	2946	
			P	-	-	8,78	8,36	7,85	7,26	6,59	5,86	5,06	4,22	3,33	
HEX1003CC	30	Q	47672	40608	34318	28733	23819	19519	15800	12581	9817	7473	5483		
		P	6,71	6,84	6,86	6,77	6,57	6,28	5,91	5,46	4,93	4,35	3,71		
	40	Q	41916	35558	29904	24922	20543	16732	13411	10556	8099	5995	4197		
		P	8,16	8,11	7,95	7,69	7,32	6,88	6,35	5,75	5,08	4,36	3,59		
	50	Q	36218	30553	25571	21169	17324	13980	11079	8588	6438	4561	2946		
		P	9,33	9,11	8,78	8,36	7,85	7,26	6,59	5,86	5,06	4,22	3,33		
HEX41	HEX851CS	30	Q	-	-	34940	29150	24050	19600	15720	12380	9500	7040	4920	
			P	-	-	6,59	6,37	6,09	5,75	5,34	4,87	4,33	3,73	3,07	
		40	Q	-	-	30720	25550	21010	17040	13600	10610	8020	5790	3840	
			P	-	-	7,51	7,18	6,78	6,32	5,79	5,20	4,54	3,82	3,03	
		50	Q	-	-	26710	22150	18150	14670	11640	8990	6700	4670	2880	
			P	-	-	8,31	7,87	7,37	6,80	6,17	5,47	4,70	3,86	2,96	
	HEX1201CC	30	Q	48830	41470	34940	29150	24050	19600	15720	12380	9500	7040	4920	
			P	6,84	6,75	6,59	6,37	6,09	5,75	5,34	4,87	4,33	3,73	3,07	
		40	Q	43170	36580	30720	25550	21010	17040	13600	10610	8020	5790	3840	
			P	7,98	7,78	7,51	7,18	6,78	6,32	5,79	5,20	4,54	3,82	3,03	
		50	Q	37740	31890	26710	22150	18150	14670	11640	8990	6700	4670	2880	
			P	8,98	8,68	8,31	7,87	7,37	6,80	6,17	5,47	4,70	3,86	2,96	
	HEX1001CS	30	Q	-	-	39840	33240	27430	22350	17930	14110	10830	8020	5610	
			P	-	-	7,52	7,27	6,95	6,55	6,09	5,55	4,94	4,26	3,50	
		40	Q	-	-	35020	29130	23950	19430	15500	12090	9140	6590	4380	
			P	-	-	8,57	8,19	7,73	7,21	6,61	5,93	5,18	4,36	3,46	
		50	Q	-	-	30450	25250	20690	16720	13260	10250	7620	5320	3280	
			P	-	-	9,47	8,98	8,40	7,76	7,03	6,23	5,36	4,40	3,38	

- Funzionamento a 50 Hz
- Per funzionamento a 60 Hz, moltiplicare la resa per 1,18

▪ Le prestazioni si basano sulla norma europea EN12900

- Non miscelare mai olii estere con olii differenti

■ Surriscaldamento massimo gas aspirato 20K

- Frequency rate 50 Hz

- For 60 Hz operation, data to be multiplied by 1,18

▪ Performance data are based on European Standard EN12900

- Never mix ester oils with different oils

■ Max suction gas superheat 20K

- Fonctionnement à 50 Hz

- Pour le fonctionnement à 60 Hz, multiplier le rendement par 1,18

▪ Les données de puissance se basent sur la norme européenne EN 12900

- Ne mélanger jamais ester huiles avec different huiles

■ Max surchauffe du gaz aspiré 20K

- Frequenz 50 Hz

- Für 60 Hz-Betrieb ist die Leistung mit 1,18 zu multiplizieren

▪ Leistungswerte basieren auf der europäischen Norm EN 12900

- Niemals Esteröl mit anderen Ölen vermischen

■ Max Sauggas-Überhitzung 20K

R1270

Serie Range Serie Serie	Modello Model Modèle Typ	Temp. Cond. Cond. Temp. Temp. Cond. Kond. Temp.	Temp. [°C]	Q [W]	Capacità frigorifera Refrigerating capacity Puissance frigorifique Kälteleistung						P [kW]	Potenza assorbita Power input Puissance absorbée Leistungsaufnahme					
					Temperatura evaporazione / Evaporating temperature Température d'évaporation / Verdampfungstemperatur [°C]												
					+5	0	-5	-10	-15	-20		-25	-30	-35	-40		
HEX35	HEX551CC	30	Q	25360	21570	18190	15200	12560	10250	8250	6530	5050	3790				
			P	5,34	5,13	4,91	4,69	4,46	4,20	3,91	3,58	3,21	2,78				
		40	Q	22440	19020	16000	13330	10980	8930	7150	5630	4310	3180				
			P	5,94	5,70	5,46	5,21	4,93	4,61	4,26	3,85	3,40	2,87				
		50	Q	19620	16590	13910	11560	9500	7710	6160	4820	3670	2670				
			P	6,53	6,27	6,00	5,71	5,38	5,01	4,59	4,11	3,56	2,94				
	HEX551CS	30	Q	-	-	21480	17940	14830	12110	9740	7700	5960	4470				
			P	-	-	5,81	5,55	5,27	4,96	4,62	4,23	3,79	3,28				
		40	Q	-	-	18900	15740	12970	10550	8450	6640	5090	3760				
			P	-	-	6,46	6,15	5,82	5,45	5,03	4,55	4,01	3,39				
		50	Q	-	-	16440	13660	11220	9100	7270	5690	4320	3140				
			P	-	-	7,09	6,74	6,36	5,92	5,42	4,85	4,21	3,48				
	HEX701CC	30	Q	29960	25480	21480	17940	14830	12110	9740	7700	5960	4470				
			P	6,31	6,06	5,81	5,55	5,27	4,96	4,62	4,23	3,79	3,28				
		40	Q	26500	22470	18900	15740	12970	10550	8450	6640	5090	3760				
			P	7,02	6,74	6,46	6,15	5,82	5,45	5,03	4,55	4,01	3,39				
		50	Q	23180	19600	16440	13660	11220	9100	7270	5690	4320	3140				
			P	7,71	7,41	7,09	6,74	6,36	5,92	5,42	4,85	4,21	3,48				
	HEX701CS	30	Q	-	-	25060	20930	17300	14120	11360	8980	6950	5220				
			P	-	-	6,77	6,47	6,14	5,79	5,39	4,94	4,42	3,83				
		40	Q	-	-	22040	18360	15120	12300	9860	7750	5930	4380				
			P	-	-	7,53	7,18	6,79	6,36	5,87	5,31	4,68	3,96				
		50	Q	-	-	19170	15930	13090	10620	8480	6630	5040	3670				
			P	-	-	8,27	7,87	7,41	6,90	6,32	5,66	4,91	4,06				
HEX751CC	30	Q	34950	29720	25070	20930	17300	14130	11370	8990	6960	5220					
		P	7,36	7,07	6,77	6,47	6,14	5,79	5,39	4,94	4,42	3,83					
	40	Q	30910	26220	22050	18360	15130	12310	9860	7750	5940	4390					
		P	8,18	7,86	7,53	7,18	6,79	6,36	5,87	5,31	4,68	3,96					
	50	Q	27040	22860	19180	15930	13090	10630	8480	6630	5040	3670					
		P	8,99	8,65	8,27	7,87	7,41	6,90	6,32	5,66	4,91	4,06					
HEX751CS	30	Q	-	-	29920	24990	20660	16870	13570	10730	8300	6230					
		P	-	-	8,08	7,72	7,34	6,91	6,44	5,90	5,28	4,57					
	40	Q	-	-	26320	21920	18060	14690	11770	9250	7090	5240					
		P	-	-	8,99	8,57	8,11	7,59	7,01	6,34	5,59	4,72					
	50	Q	-	-	19020	15630	12680	10120	7920	6020	4380						
		P	-	-	9,39	8,85	8,24	7,55	6,76	5,86	4,84						
HEX1002CC	30	Q	41750	35500	29940	25000	20670	16880	13570	10740	8300	6230					
		P	8,79	8,44	8,09	7,73	7,34	6,92	6,44	5,90	5,28	4,57					
	40	Q	-	31320	26340	21930	18070	14700	11770	9260	7090	5240					
		P	-	9,39	9,00	8,57	8,11	7,59	7,01	6,35	5,59	4,73					
	50	Q	-	-	19030	15640	12690	10130	7920	6020	4380						
		P	-	-	9,40	8,85	8,24	7,55	6,76	5,86	4,84						
HEX801CS	30	Q	-	-	34034	28426	23500	19189	15436	12205	9441	7087					
		P	-	-	9,20	8,78	8,34	7,86	7,32	6,71	6,00	5,20					
	40	Q	-	-	29939	24934	20543	16710	13388	10522	8065	5960					
		P	-	-	10,23	9,75	9,22	8,63	7,97	7,22	6,36	5,37					
	50	Q	-	-	21635	17779	14423	11511	9009	6848	4982						
		P	-	-	10,68	10,07	9,37	8,58	7,69	6,67	5,51						
HEX1003CC	30	Q	47490	40381	34056	28437	23512	19201	15436	12217	9441	7087					
		P	10,00	9,60	9,20	8,79	8,35	7,87	7,32	6,71	6,01	5,20					
	40	Q	-	35626	29961	24945	20554	16721	13388	10533	8065	5960					
		P	-	10,68	10,23	9,75	9,22	8,64	7,97	7,22	6,36	5,38					
	50	Q	-	-	21646	17790	14435	11523	9009	6848	4982						
		P	-	-	10,69	10,07	9,38	8,59	7,69	6,67	5,51						
HEX41	HEX851CS	30	Q	-	-	34040	28340	23320	18930	15120	11830	9020	6630				
			P	-	-	8,36	7,96	7,53	7,05	6,53	5,93	5,26	4,49				
		40	Q	-	-	29910	24800	20320	16400	13010	10080	7570	5410				
			P	-	-	9,14	8,67	8,15	7,58	6,93	6,20	5,38	4,45				
		50	Q	-	-	25970	21450	17480	14040	11060	8490	6270	4360				
			P	-	-	9,85	9,30	8,69	8,01	7,25	6,39	5,41	4,32				
	HEX1201CC	30	Q	47690	40470	34040	28340	23320	18930	15120	11830	9020	6630				
			P	9,13	8,75	8,36	7,96	7,53	7,05	6,53	5,93	5,26	4,49				
		40	Q	42210	35690	29910	24800	20320	16400	13010	10080	7570	5410				
			P	10,01	9,58	9,14	8,67	8,15	7,58	6,93	6,20	5,38	4,45				
		50	Q	36910	31110	25970	21450	17480	14040	11060	8490	6270	4360				
			P	10,81	10,35	9,85	9,30	8,69	8,01	7,25	6,39	5,41	4,32				
HEX1001CS	30	Q	-	-	38810	32310	26590	21580	17240	13490	10280	7560					
		P	-	-	9,54	9,08	8,58	8,04	7,44	6,76	5,99	5,12					
	40	Q	-	-	34110	28280	23160	18700	14830	11490	8620	6170					
		P	-	-	10,42	9,88	9,29	8,64	7,90	7,07	6,14	5,07					
	50	Q	-	-	29610	24450	19940	16010	12610	9670	7140	4960					
		P	-	-	11,23	10,61	9,91	9,14	8,27	7,28	6,17	4,92					

- Funzionamento a 50 Hz
- Per funzionamento a 60 Hz, moltiplicare la resa per 1,18
- Le prestazioni si basano sulla norma europea EN12900
- Non miscelare mai olii estere con olii differenti
- Surriscaldamento massimo gas aspirato 20K

- Frequency rate 50 Hz
- For 60 Hz operation, data to be multiplied by 1,18
- Performance data are based on European Standard EN12900
- Never mix ester oils with different oils
- Max suction gas superheat 20K

- Fonctionnement à 50 Hz
- Pour le fonctionnement à 60 Hz, multiplier le rendement par 1,18
- Les données de puissance se basent sur la norme européenne EN 12900
- Ne mélanger jamais ester huiles avec different huiles
- Max surchauffe du gaz aspiré 20K

- Frequenz 50 Hz
- Für 60 Hz-Betrieb ist die Leistung mit 1,18 zu multiplizieren
- Leistungswerte basieren auf der europäischen Norm EN 12900
- Niemals Esteröl mit anderen Ölen vermischen
- Max Sauggas-Überhitzung 20K

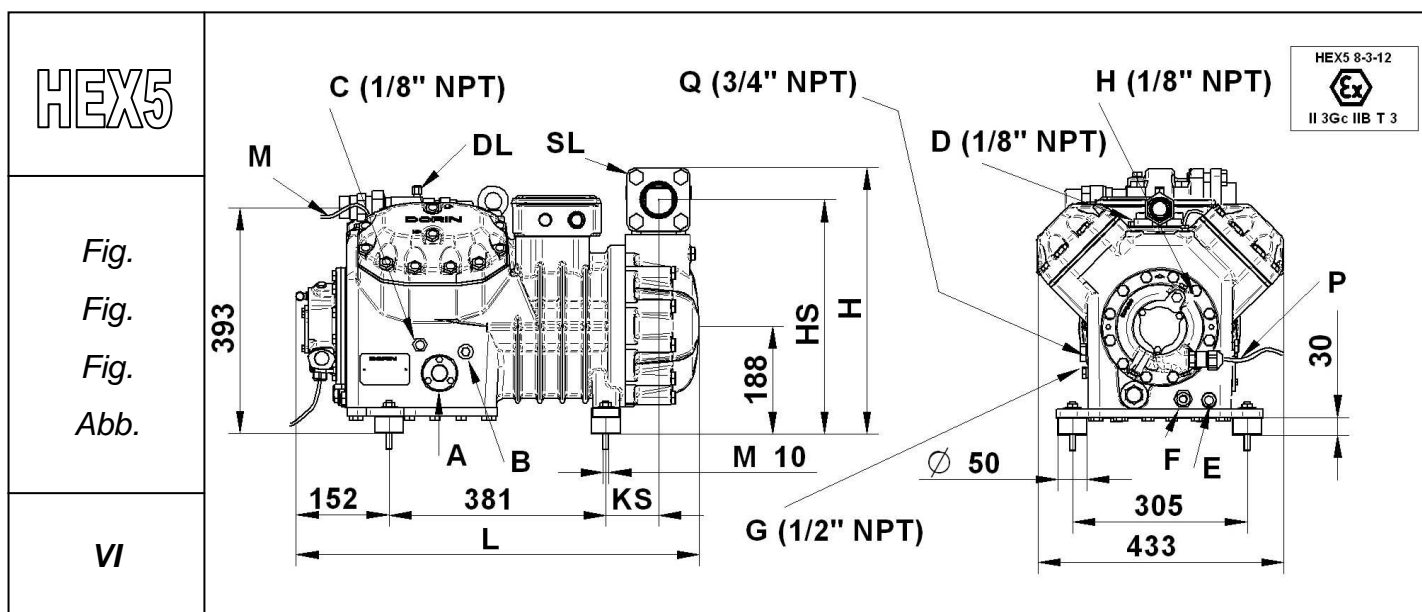
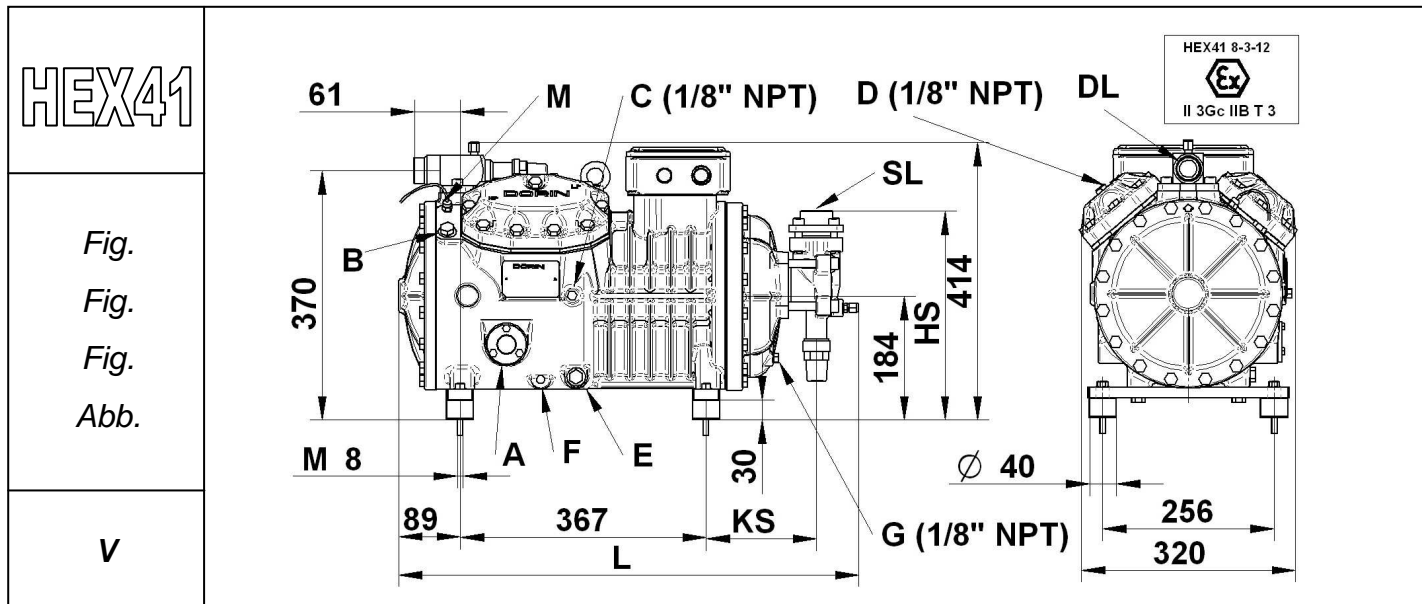

Serie Range Serie Serie	Modello Model Modèle Typ	Figura Figure Figure Abbildung	L	KS	HS
			[mm]	[mm]	[mm]
HEX41	HEX851CS	V	650	143	254
	HEX1201CC	V	650	143	254
	HEX1001CS	V	650	143	254
	HEX1501CC	V	695	166	313
	HEX1501CS	V	650	143	254
	HEX2001CC	V	695	166	313
	HEX1601CS	V	695	166	313
	HEX2201CC	V	695	166	313

Serie Range Serie Serie	Modello Model Modèle Typ	Figura Figure Figure Abbildung	L	H	KS	HS
			[mm]	[mm]	[mm]	[mm]
HEX5	HEX2000CS	VI	695	445	84	391
	HEX2500CC	VI	720	470	112	409
	HEX2500CS	VI	700	470	92	409
	HEX3000CC	VI	720	470	112	409
	HEX2700CS	VI	700	470	92	409
	HEX3200CC	VI	720	470	112	409
	HEX2900CS	VI	700	470	92	409
	HEX3400CC	VI	720	470	112	409

A - Spia Olio B - Tappo carica Olio C - Presa Bassa Pres. D - Presa Alta Pres. E - Tappo scarica olio F - Resistenza carter G - Tappo ritorno olio H - Presa alta press. pompa M - Sens. max temp. mand. P - Sens. press. diff. olio Q - Equalizzazione gas DL - Rubinetto Compressione SL - Rubinetto Aspirazione	A - Oil sight B - Oil charge plug C - Low pressure tap D - High pressure tap E - Oil drain plug F - Crankcase heater G - Oil return H - Oil pressure tap M - Max disch. temp. sensor P - Oil diff. pressure sensor Q - Gas equalisation DL - Discharge service valve SL - Suction service valve	A - Voyant d'huile B - Bouchon charge huile C - Prise basse pression D - Prise haute pression E - Bouchon vidange d'huile F - Resistance carter G - Retour d'huile H - Prise pression huile M - Sensor max temp. refoul. P - Sensor press. diff. huile Q - Egalisation de gaz DL - Vanne de refolement SL - Vanne aspiration	A - Ölschauglas B - Ölfüllstopfen C - Anschluss Niederdruck D - Anschluss Hochdruck E - Ölabaß F - Ölsumpfheizung G - Ölrückführung H - Öldruckanschluss M - Druckgasfühler P - Öldifferenzsensor Q - Gasausgleich DL - Druckabsperrventil SL - Saugabsperrventil
--	---	--	---

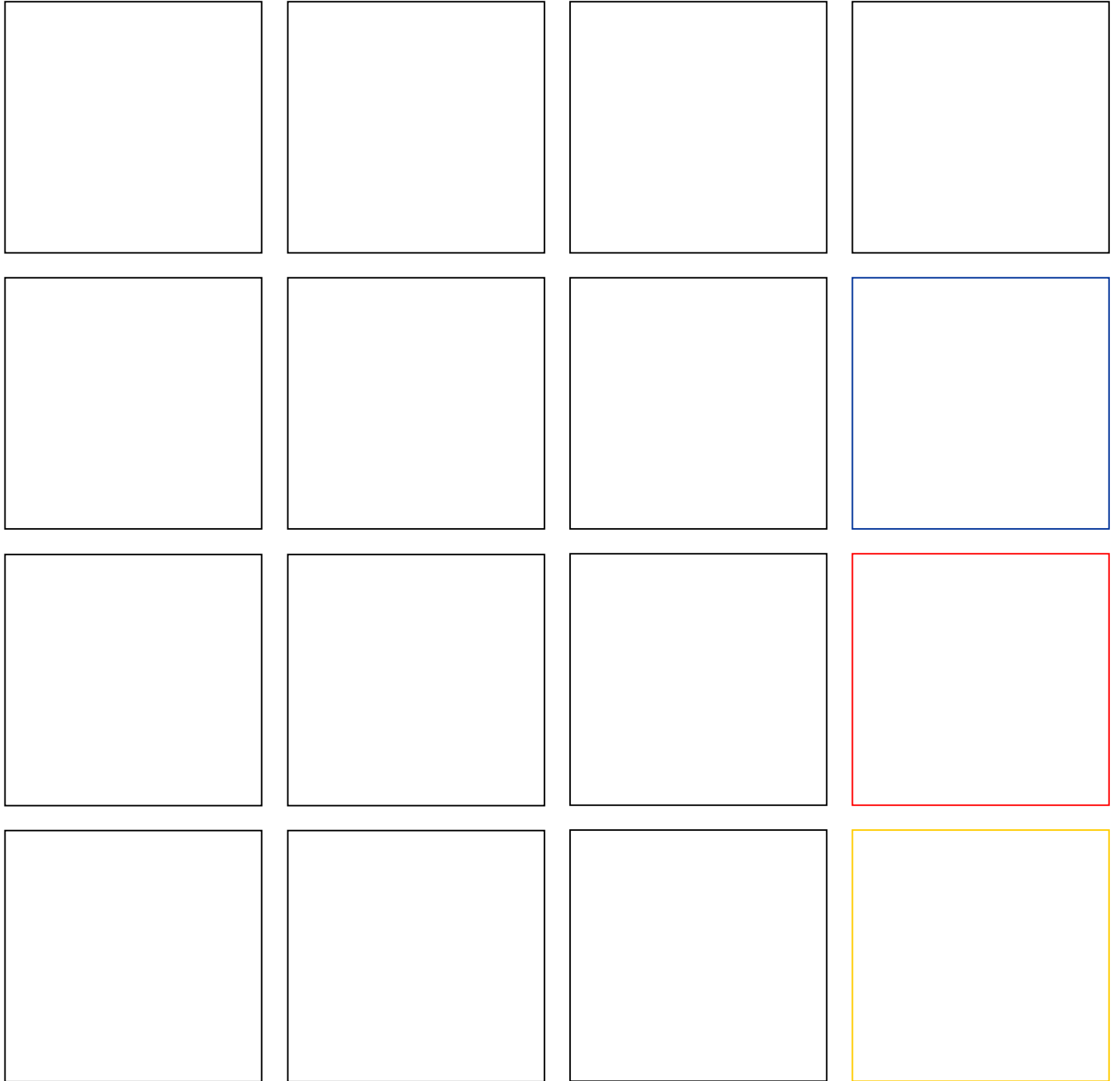

OFFICINE MARIO DORIN S.p.A.

Via Aretina, 388; 50061 Compiobbi Firenze (Italy)

Tel. +39.055.623211 - Fax +39.055.62321380

www.dorin.com - dorin@dorin.com